

## Development of Computer-Based Experiment Set on Simple Harmonic Motion of Mass on Springs

**Panjit MUSIK**

*Faculty of Science and Technology, Nakhon Si Thammarat Rajabhat University, Thailand.  
panjitmusik@yahoo.com*

### ABSTRACT

The development of computer-based experiment set has become necessary in teaching physics in schools so that students can learn from their real experiences. The purpose of this study is to create and to develop the computer-based experiment set on simple harmonic motion of mass on springs for teaching and learning physics. The average period of oscillation, the displacement-time, the velocity-time and the acceleration-time are relevant to the theory. Based on Constructivism Approach, 96 upper secondary students were tested on this computer-based experiment set. The satisfaction of the samples to their learning activities is at a high level and their pre-test and post-test scores are 9.22 and 73.80 % respectively. With the developed experiment set, learners will have an easier way to study the simple harmonic motion of a hanging mass on spring and an easier way to measure the position of an oscillating mass as a function of time. Thus, learners would get their physics concept more precisely and more quickly than ever. Learners' laboratory skills are promoted both inside and outside classrooms. Physics teachers are able to construct experiment sets on their own with low cost, and this experiment set will certainly benefit their physics teaching.

**Keywords:** Computer-based experiment set, Simple harmonic motion, Teaching and learning physics

### INTRODUCTION

The basic knowledge of physics is necessary to technological innovations because physics is the basic of technologies (Hartmann & Mittelstrass, 2002). Physics helps us to understand the operation of all devices around us such as telephones, computers, cameras, light bulbs, air-conditioners, photocopiers, etc. It also helps us to understand the causes of the natural phenomena such as rainbows, tides, floods, earthquakes, seismic sea waves, storms, etc. Although physics is necessary and useful, some students do not like to study it. They consider it too difficult and do not enjoy taking it (Ornek, Robinson & Haugan, 2008). Physics is inevitably difficult if it is solely studied through imagination. It is hard to imagine learning to do science, or learning about science without doing laboratory experiments or field work. Physics is a complex process and causes frustration for teachers and students. Therefore, the inventions of devices to represent physical concepts instead of using only physical or mathematic formulas and calculations have become indispensable for researchers.

Nowadays computer simulations have become available for a wide range of science subjects including physic. Several researches about simulation of physic theory have been done such as projectile and circular movement (Holec, Pfefferová & Raganová, 2004, Aravind & Heard, 2010, Hutem & Kerdmee, 2013). For the efficiency of computer simulation, most of the studies that compare condition with or without simulations report positive results. The computer simulation can be used to replace or enhance traditional instruction (Rutten, van Joolingen & van der Veen, 2012).

In addition to computer simulation, Computer-Based Experiment (CBE) also assists students to understand the contents of physics more easily (Trumper, 2003, David, Priscilla & Ronald, 2007). Computers help students to collect data and display the graphs in real time rapidly. Students understand the relation between the theoretical knowledge and observation. Besides, students can practice drawing graphs displaying the results of the experiments on their own or are able to analyse the involved variations later (Amrani & Paradis, 2010). CBE has been an effective innovation which benefits the process of studying physics and stimulate the students to have a concept of what they have learned. During the experiment students have their own views over the experiment which they already have done. With CBE, students have more time to be able to summarize their knowledge in physics (Pierri-Galvao, 2011).

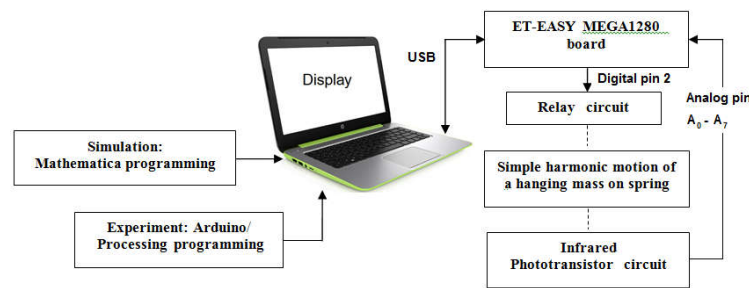
The construction and development of CBE set using computer interface consists of a microcontroller connected with a computer and an electronic circuit in order to control an experiment and to sensor other variations. The Arduino microcontroller is a very favorite make because it is easily operated. It is also and affordable. Its software can be downloaded free (Naveenkumar & Krishna, 2013, Luiz, et.al, 2013, Vasquez, 2013, Zachariadou, Yiasemides & Trougakos, 2012).

The objective of this research is to create and develop the computer-based experiment set for teaching and learning physics on simple harmonic motions of mass on the springs with an Arduino microcontroller connected with a computer and a sensor device. The relevant of experimental result to the theory could be determined together with the efficiency of the experiment set and the satisfaction of student samples.

**METHOD**

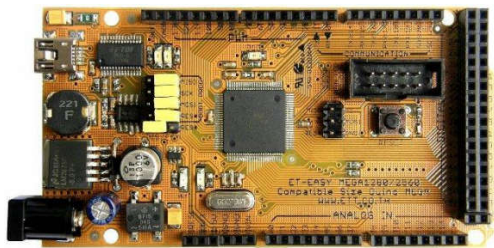
The construction and the development of the equipment for the research implementation and the collection of the data are as follows:

**Design and Construction of Computer-Based Experiment Set**

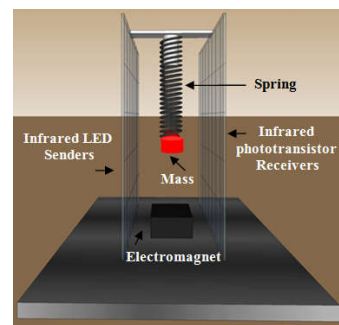


**Figure 1.** Computer-based experiment set

The computer-based experimental sets consisted of hardware, software and performance as shown in Figure 1. The hardware part is Arduino board, ET-EASY MEGA1280 (Duino Mega, Figure 2) connected to a computer or a notebook via a USB port, a relay circuit with digital pin 2, a simple harmonic motion of a hanging mass (Figure 3) on springs, an infrared phototransistor circuit with analog pins 0-7 of an Arduino board, a piece of cylindrical metal, a spring and voltage power supply. For the software, the operating system is Windows 2010 Profession. Arduino1.5.2 controls the experimental performance while Processing 1.5.1 displays output for displacement vs. time in real time graphs. Mathematica 9.0 is used to show theoretical simulation and to plot a graph of the period of oscillation vs. mass, displacement vs. time, velocity vs. time and acceleration vs. time and in order to find the best curve fitting.



**Figure 2.** AVR microcontroller board; ET-EASY MEGA1280



**Figure 3.** The construction of simple harmonic motion of a hanging mass on spring

Figure 4 is a relay switch, ET-BUSIO-RELAY that turns on or off, based on an external electrical signal (ETT Co., Ltd., 2012). Digital pin 2 of AVR microcontroller is connected with the relay and an electromagnet will be activated by making the digital pin 2 high, and it will be deactivate by making the digital pin 2 low.

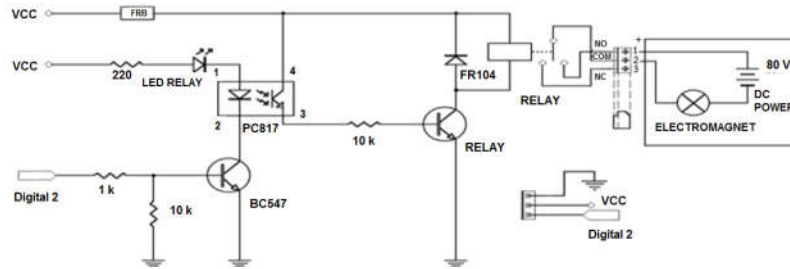


Figure 4. ET-BUSIO-RELAY

**Infrared sensor and LEDs**

An Infrared sensor is a fundamental circuit which is composed of a pair of an IR (infrared) LED sender and a phototransistor receiver shown in Figure 5. There are 2 resistances of 330 kΩ and 200 Ω, ¼ w. The 330 kΩ is for the receiver and the 200 Ω is for the sender. Electric power of the system is 5 volt of a direct current. When the infrared reaches the phototransistor, the output voltage is at 0 volt and when the infrared is obstructed by an object, the output voltage changes to 5 volt. The signals of the output voltage are used to measure the time of an oscillating mass at various points with an Arduino program.

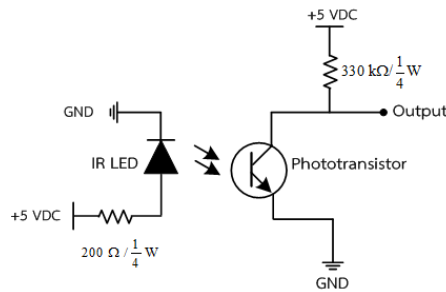


Figure 5. Infrared sensor circuit

The 8 infrared LEDs are fixed in a row (Figure 6), each of which is parallel connected with a range of 1.2 centimeters so that the moving object will never go out of the detected area. In Figure 8, 8 phototransistors are also fixed in a row. The output voltage is connected to IC or gate CD4078BE since each pair of the senders and the receiver has to work compatibly.

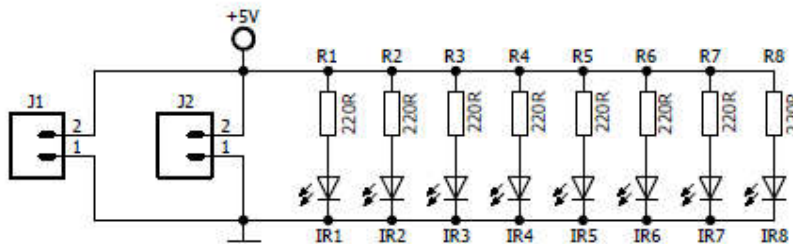
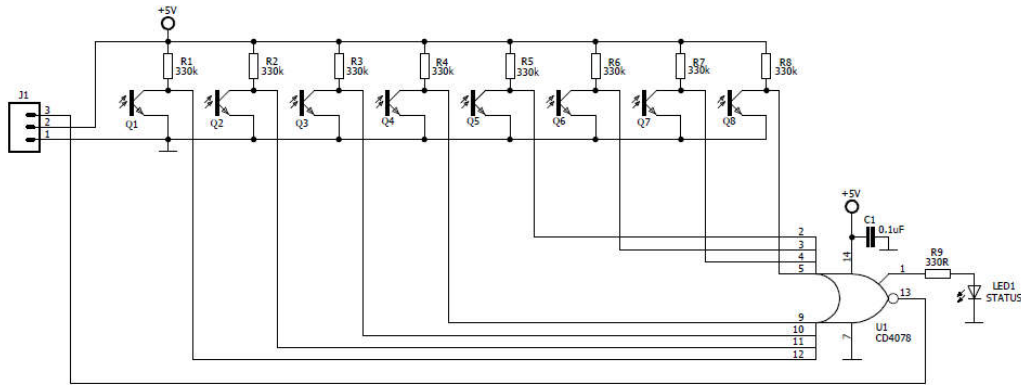
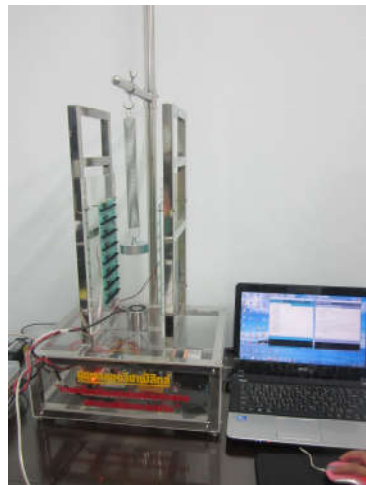


Figure 6. Infrared LEDs circuit



**Figure 7.** Infrared phototransistor receiver circuit

The infrared sensor was designed in a sensor plate of 30 centimeters (high)  $\times$  10 centimeters (wide). There are also 8 rows of 8 phototransistors fixed along the height opposite to 8 rows of 8 infrared LEDs, each of which is 3 centimeters long between one another. When the infrared is sent from the sender, the receiver in the opposite side will be on charge to work.



**Figure 8.** Computer-based experiment set for simple harmonic motion of mass on springs

Figure 8 shows the computer-based experiment set for simple harmonic motion of mass on spring experiment. A microcontroller is connected to a computer and an electronic circuit in order that the time at any fixed points will be read. Then the real time graph of displacement vs. time of the steel ball will be displayed. There is a relay switch to turn on and off the circuit. The cylindrical metal at the end of the spring is caught when the switch is on and released when the switch is off. When the cylindrical metal is released from 0.30 m height, it moves in simple harmonic motion through the infrared phototransistors and makes the voltage output of the infrared receivers change from 0 to 5 volt. The output from the receivers is sent to the microcontroller. Arduino program takes charge to check for the time the object consumes in five periods, and then the data are stored in the computer. Figure 9, Processing 1.5.1 displays the output for displacement vs. the time in real time experiment.

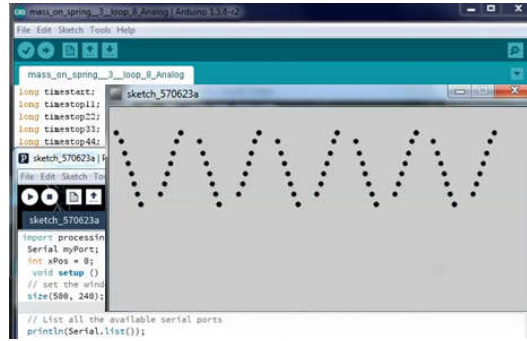


Figure 9. Graphs of displacement vs. the time in the real time graphs.

### Simple harmonic motion of mass on spring theory

In Figure 10, when the mass starts at  $x = 0$  at the time when  $t$  is 0. The analysis shows that the period ( $T$ ) of the motion depends on the spring constant ( $k$ ) and the mass ( $m$ ) in the following fashion:

$$T = 2\pi\sqrt{\frac{m}{k}} \quad (1)$$

The angular frequency is,

$$\omega = \frac{2\pi}{T} = 2\pi f \quad (2)$$

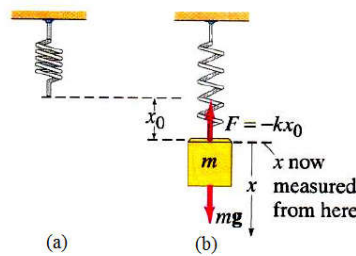


Figure 10. (a) The free spring is hung vertically. (b) The mass is attached to the spring at the equilibrium position, which occurs when  $\sum F$  equals 0 or  $\sum F = kx_0 - mg$ . (Giancoli, 2000)

where the displacement is given by:

$$x(t) = A \cos(\omega t + \phi) \quad (3)$$

taking two time derivatives,

$$v(t) = \frac{dx}{dt} = -\omega A \sin(\omega t + \phi) \quad (4)$$

$$a(t) = \frac{dv}{dt} = -\omega^2 A \cos(\omega t + \phi) \quad (5)$$

where  $x(t)$ ,  $v(t)$  and  $a(t)$  are displacement, velocity and acceleration at time  $t$ ,  $\omega$  is the angular frequency.

The maximum displacement is called the amplitude,  $A$ . The constant  $\phi$  is called the initial phase constant or phase angle.

### Experimental procedure

The spring constants,  $k$  of the springs are  $k_1$ ,  $k_2$  and  $k_3$ . Determination of the spring constant by Hooke's law as follows:  $k_1=3.40544$  N/m,  $k_2=7.53294$  N/m and  $k_3=12.17026$  N/m. The spring constant can be determined by measuring the period of oscillation for different hanging masses from computer-based experiment set, as detailed below.

1. Hang one end of a  $k_1$  spring to the hook of the set and hang a cylindrical metal of  $m=0.095$  kg at the other end of the spring.

2. Adjust the distance from the object to the start to be the same length as the most extending spring after hanging the object.
3. Switch the power on and run the Experiment Arduino program and results Processing program respectively.
4. Set the object to the start point.
5. Put off the switch to launch the object.
6. Observe the points which display how the object moves, record the time for 5 periods' movement of the object, and then switch off the program.
7. Change the object to 0.100 kg, 0.125 kg, 0.135 kg, 0.150 kg, 0.163 kg, 0.175 kg, 0.190 kg and 0.200 kg, and then repeat 2-5.
8. Change the spring to  $k_2$ , hang a cylindrical metal of each mass at a time to the hook, and then repeat 2-5.
9. Change the spring to  $k_3$ , hang a cylindrical of 0.135 kg to the hook, and repeat 2-5.
10. Change the object to 0.150 kg, 0.163 kg, 0.175 kg, 0.190 kg and 0.200 kg, and repeat 2-5.

### The supplemental physics lessons

The supplemental physics lessons were designed due to Constructivism Approach for upper secondary school students in order that the students chosen as samples would have their handbooks for the experiment. The supplemental physics lessons contain the content of simple harmonic motion of a hanging mass on spring. There are 2 types of experiment in students' book. One is real experiment with the computer-based experimental set and the other is the experiment of theoretical calculation or in other words is a graph simulation of the object's motion for the data. In experiment part, topic, objectives, experiment's tools, procedure, recording tables, analyzing part, concluding part, post experiment questions, and revision exercises are provided for the students.

### The computer-based experiment set was tested in physics classes with Constructivism Approach

The computer-based experiment set together with the lesson is tested in physics classes according to Constructivism Approach. To find out whether the effectiveness of the experiment set together with the lesson reaches the fixed criterion at 70/70. The sample group was composed of 96 upper secondary students studying science and mathematics in grade 10 at Princess Chulabhorn's College Nakhon Si Thammarat. The Pre-test, the post-test, the post experiment exercise, the achievement test, and the satisfaction test were assigned to use during 6 periods of the instruction. The process of learning activities of Constructivism Teaching (Matthews, 1994), are as follow;

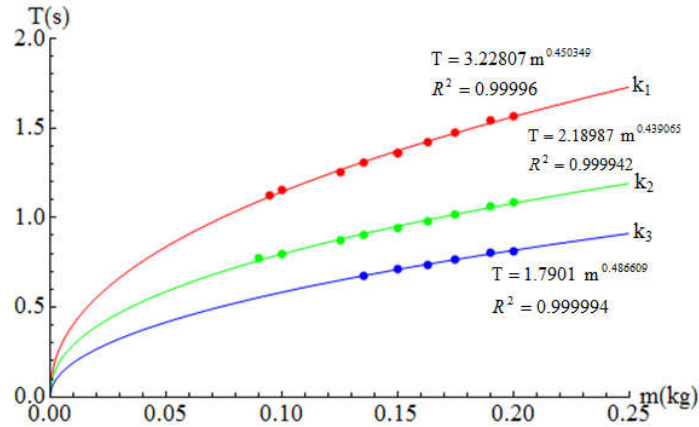
1. Orientation-purpose and motivation for learning
2. Elicitation-clarify ideas or criteria for the topic
3. Restructuring Ideas-Clarification, exchange of ideas, evaluation of the new ideas
4. Application of the ideas-use the ideas in a variety of situations (new and old)
5. Review-reflect on how ideas have changed or developed

## RESULTS

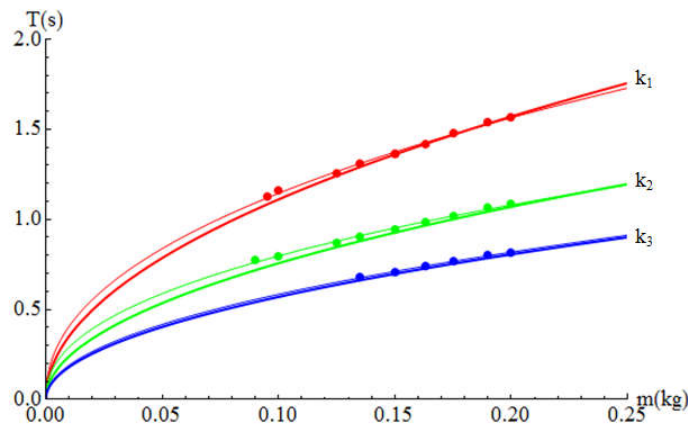
The trial of experimental set yields the result as shown in the table below. The relationship of the period and the mass in a curve was shown Figure 11. Increasing the mass resulted in increasing the period in non-linear regression. When the spring constant is increase, the period of an oscillation mass on a spring is decrease. The experiment period values were compared with the theoretical values (Figure 12). The graphs show significantly relevant between experimental result and the theoretical calculation result.

**Table 1.** The period of mass on a spring.

Mass, $m$ (kg)	Period, $T$ (s)		
	Spring 1( $k_1$ )	Spring 2 ( $k_2$ )	Spring 3( $k_3$ )
0.095	1.1251	0.7733	
0.100	1.1573	0.7981	
0.125	1.2557	0.8695	
0.135	1.3065	0.9046	0.6766
0.150	1.3633	0.9425	0.7096
0.163	1.4208	0.9826	0.7393
0.175	1.4757	1.021	0.7676
0.190	1.5396	1.0638	0.8008
0.200	1.5691	1.0851	0.8157



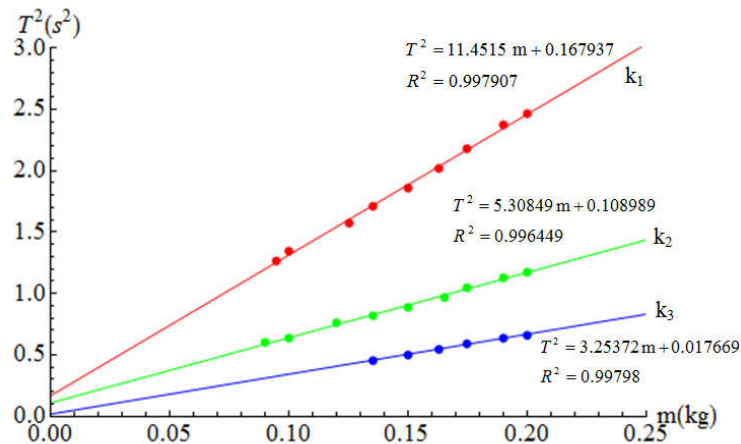
**Figure 11.** Graph of the spring period vs. the mass attached to the springs. The dots represent the value taken from the experiment whereas the lines are obtained from the curve fitting.



**Figure 12.** The experimental result is compared with the theoretical calculation result. The dots represent the value taken from the experiment whereas the lines are obtained from the curve fitting. The thick lines represent theoretical calculation result.

The graph in Figure 13 shows the period squared as a function of mass. As the mass on the spring increases, the period squared increases proportionally. The relationship of  $T^2$  and mass appears to be linear.

The equation for our experiment was  $T^2 = 11.4515 m + 0.167937$  ,  $T^2 = 5.30849 m + 0.108989$  and  $T^2 = 3.25372 m + 0.017669$  . Then the springs are  $k_1=3.44744$  N/m,  $k_2=7.43685$  N/m and  $k_3=12.1333$  N/m. respectively.



**Figure 13.** The graph shows the relationship of period squared ( $T^2$ ) versus mass ( $m$ ).

The dots represent the value taken from the experiment whereas the lines are obtained from the linear fitting.

The calculation of the percentage difference between the  $k$ 's are obtained from the Hooke's laws and the oscillating masses.

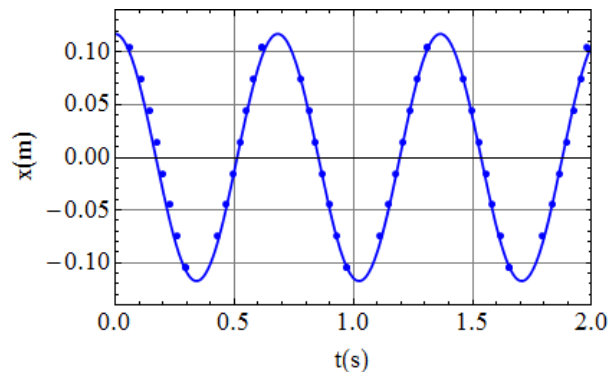
$$\%Difference = \frac{|Difference\ of\ the\ two\ values|}{Average\ of\ two\ values} \times 100 \quad (6)$$

After that the means of the spring constant is conducted by using Hooke's law and the period of oscillation of mass on the springs is measured. The different percentage is  $k_1=1.22576\%$ ,  $k_2=1.28377\%$  and  $k_3=0.30419\%$ . The average percentage difference is  $0.93791\%$ .

#### The relationship of displacement-time, velocity-time, and acceleration-time.

The experiment result for displacement-time was obtained by using  $k=12.133\text{ N/m}$ , and  $m=0.135\text{ kg}$ . Graphed with Mathematica 9.0 as shown in Figure 14, dots represent experimental value whereas lines were obtained by linear fitting. The equation for displacement is as follows:

$$x(t) = 0.117136 \cos(9.20876t) \quad (7)$$



**Figure 14.** Graph of displacement-time

The velocity of the simple harmonic of mass on springs at time  $t$  is then obtained by differentiating the  $x(t)$ . The equation for velocity as in the equation (8).

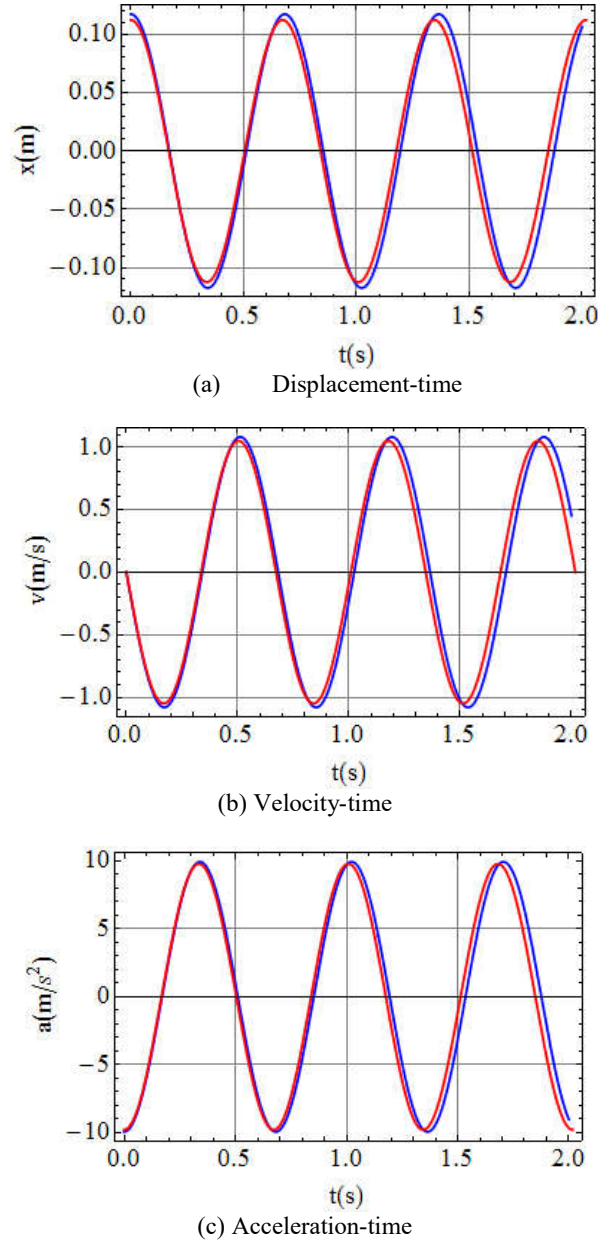
$$v(t) = -1.08031 \sin(9.20876t) \quad (8)$$



The acceleration of the simple harmonic of mass on spring at time  $t$  is then obtained by differentiating the  $v(t)$ . The equation for acceleration is as in the equation (9).

$$a(t) = -9.94834 \cos(9.20876t) \quad (9)$$

Figure 15 shows significantly relevant between experimental result and the theoretical calculation result of displacement-time, velocity-time, and acceleration-time.



**Figure 15.** (a) Displacement-time, (b) velocity- time and (c) acceleration-time of the simple harmonic of mass on spring. The blue lines represent experimental result and the red lines represent theoretical calculation results.

**Effectiveness of the computer-based experimental set with the Physics lesson.**

To determine the effectiveness of the computer-based experiment set together with supplement lessons when using in Physics class, the pre-test, post-test, post experiment exercise, and achievement test and satisfaction test

were assigned to 96 student samples during 6 periods of the instruction. As shown in Table 2, the average post-test scores are higher than pre-test. The achievement score was determined during laboratory activity and from lab report including post-exercise question, discussion and conclusion. The post experiment test score compared with the achievement test score is 9.22/73.80. Based on the scores, it proves that the effectiveness of the experiment set together with the lesson perfectly reaches the criterion of 70/70. The satisfaction of the samples groups with their learning activities is at a high level.

**Table 2.** Pre and post achievement scores

Level Grade 10 4 classes	Number of samples (N)	Pre-test		Post-test		t-test
		$\bar{x}$	S.D.	$\bar{x}$	S.D.	
4/1	24	2.92	2.12	35.83	4.13	39.47**
4/2	24	0.17	2.21	33.83	4.46	34.64**
4/5	24	4.25	3.77	33.25	4.47	31.49**
4/6	24	1.92	1.25	34.58	3.83	37.84**
Total	96	2.31	2.51	34.37	4.23	39.47**

\*\* Significant at 0.01

**Satisfaction to the Computer-based experimental set together with the lesson.**

The satisfaction test was invented to find out level of satisfaction to the computer-based experimental set with the lesson through the following topics and the results are shown below.

**Table 3.** Satisfaction mean scores to the Computer-based experimental set together with the lesson.

Number	Inquired topic	Satisfaction Score			
		$\bar{x}$	S.D.	Level of quality	Ranking
1	Instructor	3.71	0.81	high	3
2	Lesson content and learning activity	3.64	0.87	high	4
3	Documents and teaching aids	3.92	0.81	high	1
4	Learning atmosphere	3.86	0.82	high	2
5	Learning achievement and what can apply from learning	3.57	0.90	high	5
Satisfaction mean of 5 topics		3.73	0.84	high	
Holistic satisfaction		3.80	0.87	high	

The table displays satisfaction scores to the computer-based experimental set together with the lesson in every inquiring topic at a high level. The satisfaction mean scores for all 5 topics reveals at a high level of  $\bar{x} = 3.73$  and  $S.D. = 0.84$ . For holistic satisfaction, mean score also reveals at a high level of  $\bar{x} = 3.80$  and  $S.D. = 0.87$ .

**DISCUSSION**

The computer-based experiment set for simple harmonic motion of mass springs is developed in this study and used for teaching student samples. For the experiment set, the signals of the output voltage of the infrared sensor circuit is used to measure the time of an oscillating mass at various points and the Arduino program record the time on computer. The period of oscillation can be measured with high accuracy and significantly relevant to theory. Comparing of this results to the studies using an ultrasonic distance sensor to measure the position of oscillation of masses (Amrani & Paradis, 2010, Galeriu, Edwards & Esper, 2015), indicate similar accuracy. In addition, it has greatly benefited to students, enabling them to collect, display, and analyzes data in real-time (Zachariadou, Yiasemides & Trougakos, 2012). By fixing the position of moving objects and measuring the time of oscillation, the student samples can understand the experimental concept more clearly and quickly. Similar to several studies about computer-based experiment set, the academic achievement of student samples is increasing and they are satisfied with it. The experiment set can be easily and inexpensively constructed. Besides, physics teachers are able to make this device and schools can save a lot of money on buying laboratory apparatuses.

## CONCLUSIONS

The development of the computer-based experiment set on simple harmonic motion of mass on springs has made use of an Arduino microcontroller connected with a computer and the infrared sensor. The experiment setup is a simple and inexpensive construction. These tools are applied in a variety of appropriate tasks. The average percentage difference of between the determinations of the spring constant from Hooke's law and the period of oscillation of masses is 0.93791 %. The displacement, velocity and acceleration of the oscillations as a function of time are relevant to the theory. Testing of the experiment set in classes with Constructivism Approach resulted to higher post-test score than pre-test and the satisfaction score according to the students' attitude is at a high level. The computer-based experiment set has become necessary in teaching physics in schools so that students are able to learn from their real experiences. This approach helps them to comprehend physics conception and develop their learning skills. In the future, we plan to construct a physics laboratory set on force and motion for the upper secondary level using computer-based experiment learning of Constructivism Approach.

## ACKNOWLEDGEMENTS

This work is supported by Nakhorn si Thammarat Rajabhat University and the National Research Council of Thailand (NRCT). I would like to thank Princess Chulaphorn College School for providing 96 samples and physics classes for this trial. My heartfelt thanks go to Mr. Nattapol Jayangkool for his assistance in the construction of a computer-based set. Lastly, I would like to thank Mrs. Chongdee Naktewan for giving useful comments on my work.

## REFERENCES

- Amrani, D. & Paradis, P. (2010). Use of Computer-Based Data Acquisition to Teach Physics Laboratories: Case study Simple harmonic Motion. *Latin American Journal of Physics Education*. 4(3), 511-514.
- Aravind, V.R. & Heard, J.W. (2010). Physics by Simulation: Teaching Circular Motion using Applets. *Latin American Journal of Physics Education*. 4(1), 35-39.
- David, R.S. Priscilla, W.L. & Ronald, K.T. (2007). Real Time Physics: active learning labs transforming the introductory laboratory. *European journal of physics*. 28, S83-S94.
- ETT Co., Ltd. (2013). *User's manual of Board Microcontroller ET-EASY MEGA1280 (Duino Mega)*. Retrieved 5 July, 2013 from: www.ett.co.th.
- ETT Co., Ltd. (2012). *ET-BUSIO-RELAY*. Retrieved 5 June, 2013 from: www.ett.co.th.
- Galeriu, C., Edwards, S. & Esper, G. (2015). An Arduino Investigation of Simple Harmonic Motion. *The Physics Teacher*. 52, 157-159.
- Giancoli, C.D. (2000). *PHYSICS for SCIENTISTS & ENGINEERS*. USA: Prentice Hall.
- Hartmann, S. & Mittelstrass., J. (2002). *Physics is Part of Culture and the Basis of Technology*. Physics-Physics Research: Topics, Significance and Prospects. Bonn: DPG 2002, 195-198.
- Holec, S. Pfefferová, M.S. & Raganová, J. (2004). Computer Simulations in Mechanics at the Secondary School. *Informatics in Education*. 3(2), 229-238.
- Hutem, A. & Kerdmee, S. (2013). Physics Learning Achievement Study: Projectile, using Mathematica program of Faculty of Science and Technology Phetchabun Rajabhat University Students. *European Journal of Physics Education*. 4(3), 1-12.
- Luiz, A., et al. (2013). A Low-Cost and Simple Arduino-Based Educational Robotics Kit. *Cyber Journals: Multidisciplinary Journals in Science and Technology*. 3(12).
- Matthews, M. (1994). Discontent with constructivism. *Studies in Science Education*. 24, 165-172.
- Naveenkumar, R. & Krishna, P. (2013). Low Cost Data Acquisition and Control using Arduino Prototyping Platform and LabVIEW. *International Journal of Science and Research (IJSR)*, 2(2), 2319-7064.
- Ornek, F. Robinson, W. & Haugan, M. (2008). What makes physics difficult?. *International Journal of Environmental & Science Education*. 3(1), 30-34.
- Pierr-Galvao, M. (2011). Restructuring the introductory physics lab with the addition of computer-based laboratories. *Journal of Natural Science, Biology and Medicine*. 2(2), 164-167.
- Rutten, N. van Joolingen, W. R. & van der Veen, J. T. (2012). The learning effects of computer simulations in science education. *Computer & Education*. 58, 136-153.
- Trumper, R. (2003). The Physics Laboratory-A Historical Overview and Future Perspectives. *Science & Education*. 12, 645-670.
- Vasquez, H. (2013). *Integration of Sensors and Low-Cost Microcontrollers into the Undergraduate Mechanical Engineering Design Sequence*. 120<sup>th</sup> ASEE Annual Conference & Exposition.
- Zachariadou, K., Yiasemides, K. & Trougakos, N. (2012). A low-cost computer-controlled Arduino-based educational laboratory system for teaching the fundamentals of photovoltaic cells. *European Journal of Physics*. 33, 1599-1610.